

[www.cb-italy.com](http://www.cb-italy.com)



F O R N I P I Z Z A

P I Z Z A O V E N S  
F O U R S A P I Z Z A  
P I Z Z A Ö F E N





Sistema Qualità  
Certificato UNI EN ISO 9001  
Cert. Num. 9105.CB01

### FORNI PIZZA ELETTRICI

### ELECTRICAL PIZZA OVENS

### FOURS A PIZZA ELECTRIQUES

### ELEKTRO-PIZZA-ÖFEN

#### Caratteristiche

Regolazione indipendente della temperatura del cielo e della platea

#### Characteristics

Independent temperature regulation of the top and of the bed

#### Caractéristiques Techniques

Réglage indépendant de la température dans la partie supérieure (voûte) et dans la celle inférieure (sole)

#### Merkmale

Unabhängige Temperatureinstellung für obere und untere Kammerheizungen

#### Temperatura 0° - 450°

Cottura diretta al suolo o in teglia

#### Temperature 0° - 450°

Cooking with or without baking-pan

#### Température 0° - 450°

Cuisson directe sur la pierre lavique ou dans plaques

#### Temperatur 0° - 450°

Aufheizen mit oder ohne Beckblech

Sportello ergonomico a battente incernierato in basso

Flap door

Porte d'enfournement à battant

Klapptür

Termostato di sicurezza a pannello

Safety thermostat

Thermostat de sécurité

Sicherheitsthermostat

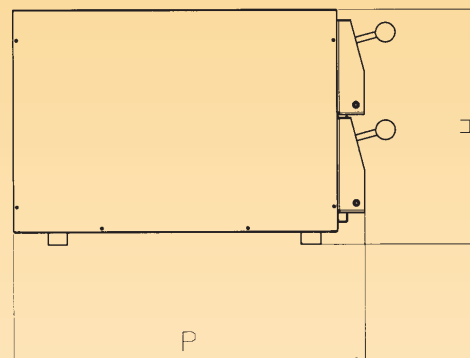
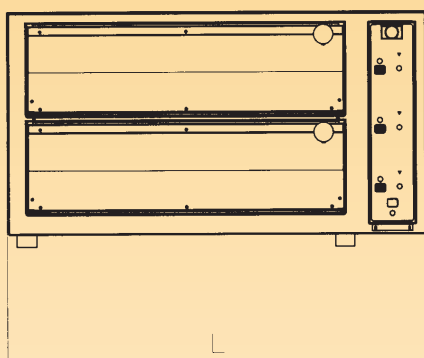
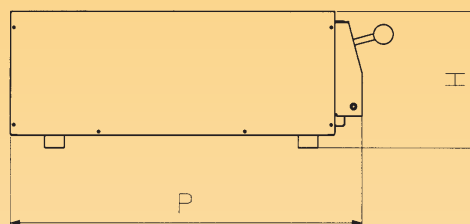
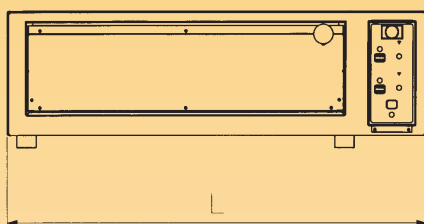

Forno pizza elettrico Electrical pizza oven Four à pizza électrique Elektro-Pizza-Ofen	Larghezza Width Largeur Breite	Profondità Depth Profondeur Tiefe	Altezza Height Hauteur Höhe	N. camere N. chambers N. chambres N. Kammern	Larghezza camera Chamber width Largeur chambre Kammerbreite	Profondità camera Chamber depth Profondeur chambre Kammertiefe	Altezza camera Chamber height Hauteur chambre Kammerhöhe	N. Pizze N. Pizzas N. Pizzas N. Pizzen	Tensione Voltage Tension Spannung	Potenza Power Puissance Leistung
4-PIZZA CB 500 **	750 mm	620 mm	280 mm	1	505 mm	520 mm	110 mm	4	230V~ 230V 3~ 400V 3N~	3 KW
4-PIZZA CB	870 mm	720 mm	280 mm	1	625 mm	620 mm	110 mm	4	230V~ 230V 3~ 400V 3N~	4 KW
8-PIZZA CB	870 mm	720 mm	480 mm	2	625 mm	620 mm	110 mm	8	230V 3~ 400V 3N~	6 KW
8-PIZZA CB 4 TER*	870 mm	720 mm	480 mm	2	625 mm	620 mm	110 mm	8	230V 3~ 400V 3N~	8 KW

#### Cavalletto per Stainless steel support for Chevalet pour Untergestell für

Larghezza Width Largeur Breite	Profondità Depth Profondeur Tiefe	Altezza Height Hauteur Höhe
---	--	--------------------------------------

4-PIZZA CB 500	750 mm	620 mm	960 mm
4-PIZZA CB	870 mm	720 mm	960 mm
8-PIZZA CB			
8-PIZZA CB 4 TER	870 mm	720 mm	900 mm

\* n. 4 termostati e n. 4 resistenze  
\*\* in questo modello n. 4 pizze si intendono con dimensioni pizza Ø inferiore a 30 cm

\* n. 4 thermostats and n. 4 heating elements  
\*\* this model is for 4 pizzas with Ø less than cm. 30

\* nr. 4 thermostats et nr. 4 résistances  
\*\* ce modèle est pour nr. 4 pizzas de Ø inférieur à 30 cm.

\* Nr. 4 Thermostate und Nr. 4 Heizelemente  
\*\* dieses Modell ist für Nr. 4 Pizzen mit Ø kleiner als cm. 30

La ditta CB si riserva il diritto di qualsiasi modifica per il miglioramento delle sue apparecchiature.  
Document non contractuel. La CB pratique une politique d'amélioration permanente et se réserve le droit de modifier ses appareils sans notification préalable.  
CB reserves the right to change its equipment in order to improve it.  
Änderungen für Verbesserungen vorbehalten.

